

TITLE: RecoveryBoard	
Document Number:	REV:
Date: 4/29/2020 5:01 PM	Sheet: 1/2

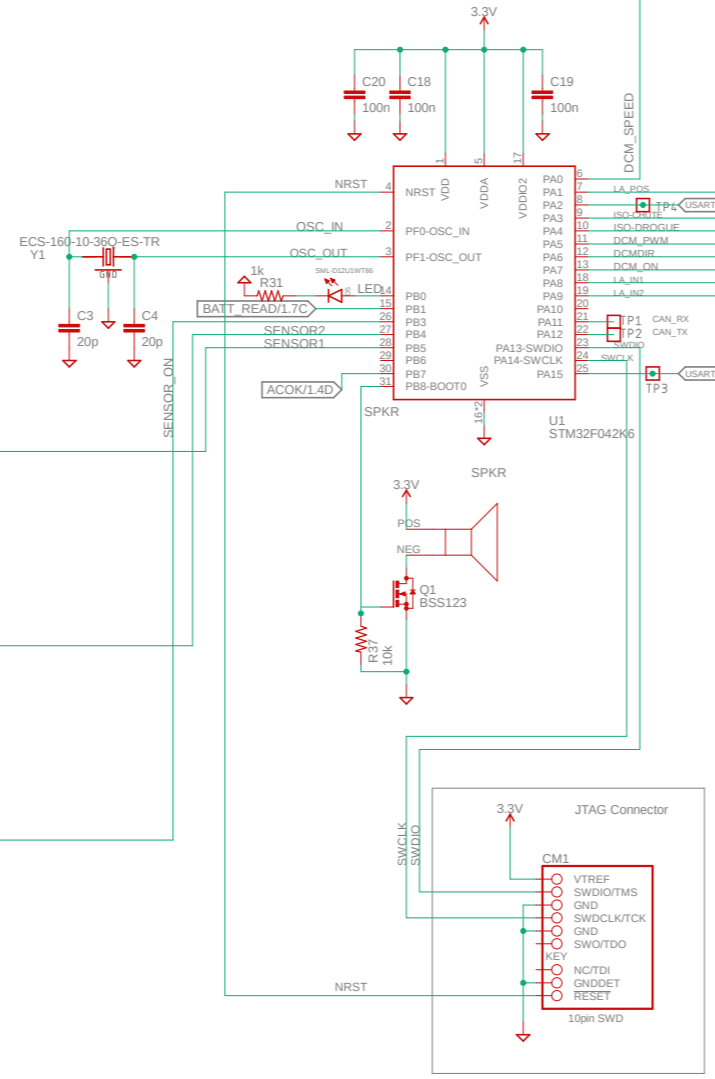
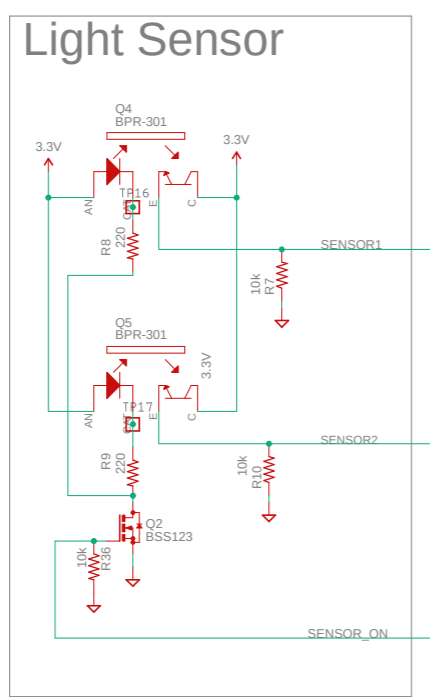
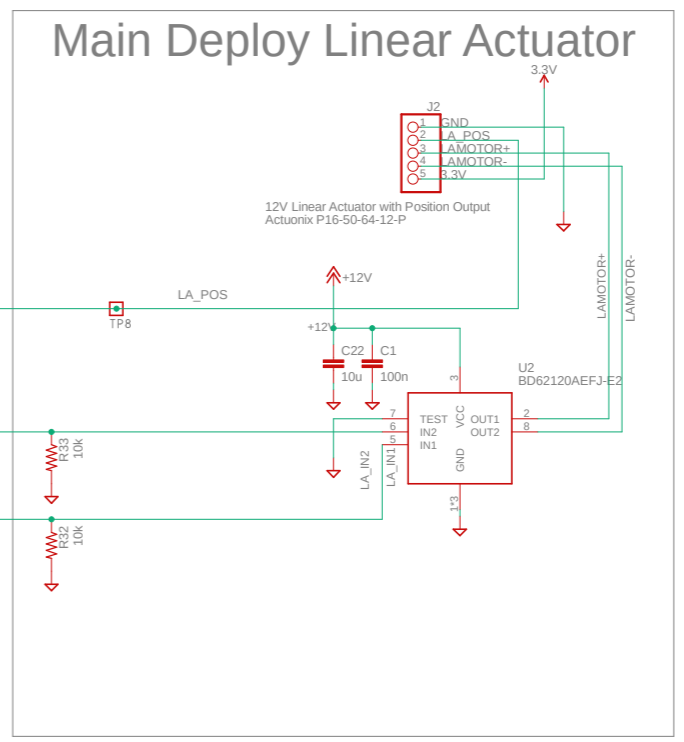
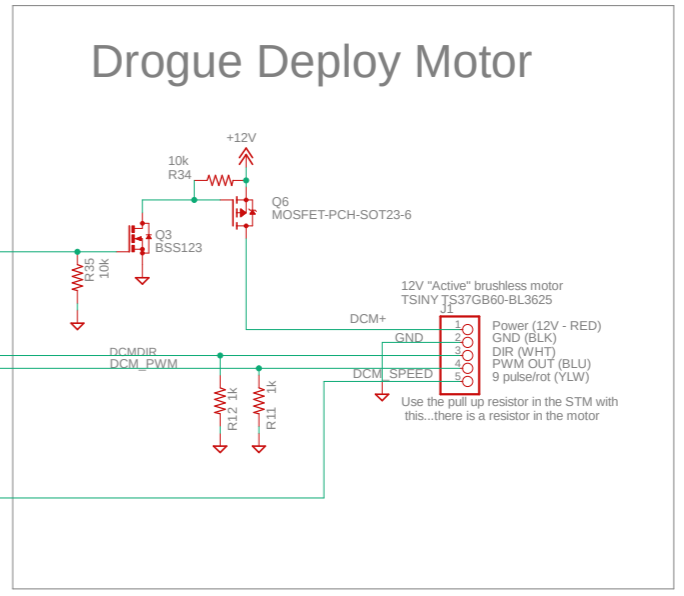
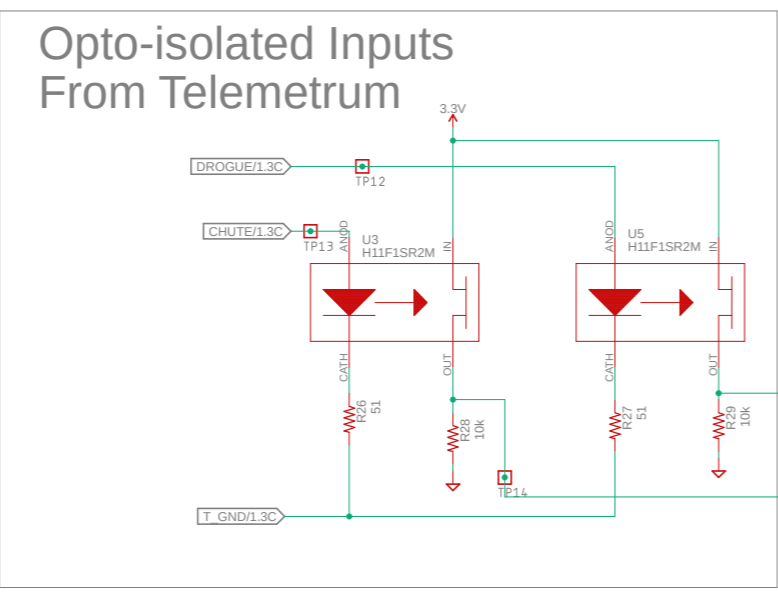

TITLE: RecoveryBoard	
Document Number:	REV:
Date: 4/29/2020 5:01 PM	Sheet: 2/2